

Evolution Low Profile Box

Assembly guide for the Low Profile Box (LP-BOX) accessory



IMPORTANT NOTE

These instructions will assist you with assembling the Low Profile Box, a component of the Evolution Low Profile Wine Rack System. Please refer to Low Profile Wine Rack System instructions for full installation details, including all required parts.

[INCLUDED] BOX ASSEMBLY

- (2) X Style Sides
- (4) Horizontal Supports
- (1) Shelf Base
- [optional] (1) Shelf Top
- [optional] (qty varies) Bottle Stop

REQUIRED TOOLS

- Power drill with low-torque setting
- Phillips head drill bit
- Phillips head screwdriver
- Level or Square
- Rubber Mallet
- Pencil or Marker
- Clamps

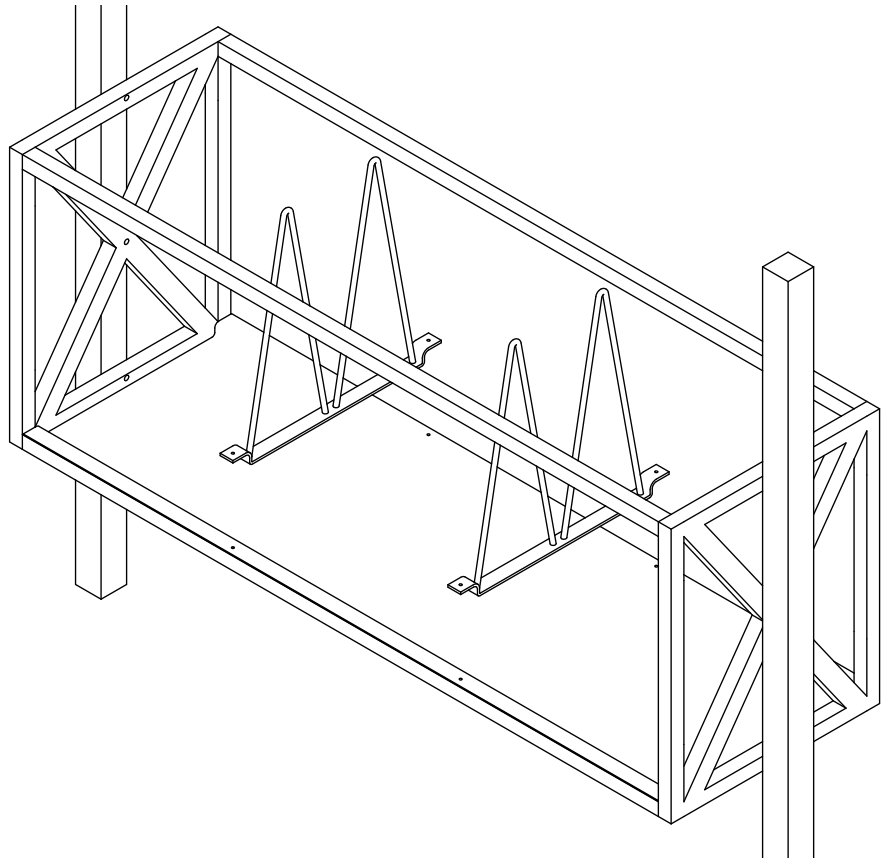

1. START THE LOW PROFILE

Follow Low Profile Wine Rack System Installation Instructions and install entire system, leaving space to add one or more Low Profile Box assemblies. Each Box requires 20" of vertical space.

2. IDENTIFY THE PIECES

Each Low Profile Box assembly is comprised of (2) X Sides, (4) Horizontal Supports, and (1) Shelf Base. Optional upgrades include (1) Shelf Top, and up to (11) Bottle Stops.

3. CONNECT THE BEAMS

Attach (1) Horizontal Support to the c-Channel of the first X Side, ensuring c-channel is fully set inside the Support. Repeat with the remaining (3) Horizontal Supports. A rubber mallet may be required. (FIGURE A).

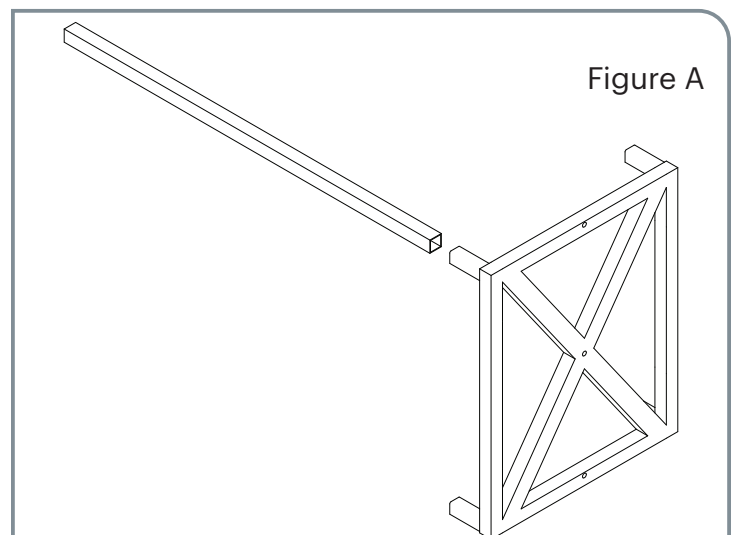



4. CLOSE THE BOX

Lay the assembly on its side with Supports facing up. Attach the remaining X Side to the open end of the Horizontal Supports. A rubber mallet may be required to set in place. (FIGURE B)

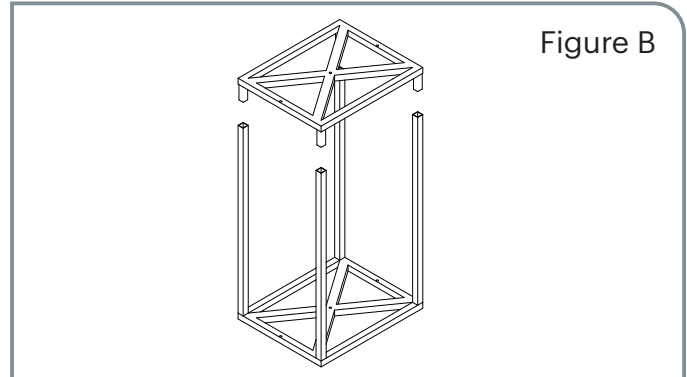

5. PREDRILL FOR STOPS [optional]

If installing Bottle Stops, insert Shelf Base in the bottom of the Box. Set Bottle Stops in desired locations (using actual wine bottles as a guide is helpful). Mark the mounting locations on the front and back of the Shelf Base. (FIGURE C)

Remove the Bottle Stops and, using provided drill bit, pre-drill assembly locations. Remove the Shelf.

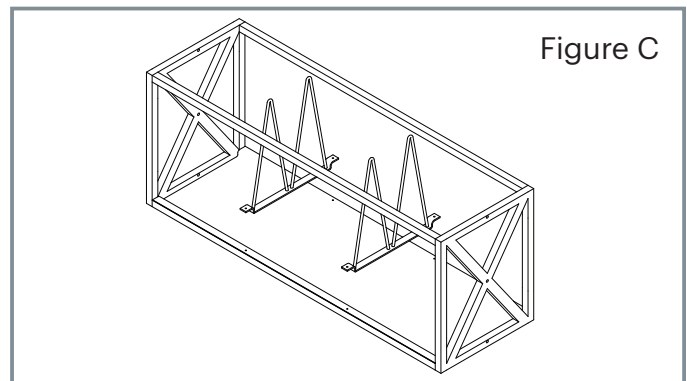

6. PREDRILL LOW PROFILE ASSEMBLY

NOTE: Do not insert Shelf Base, Shelf Top, or Bottle Stops until finishing this step.

Set the assembled Box in place in the fully installed Low Profile display using clamps.

Ensure the Box is facing up by checking location of Box's predrilled holes (the top is indicated by the hole being closest to the top edge).

Ensure level, and mark assembly hole locations. Remove Box and predrill at marks. (FIGURE D)

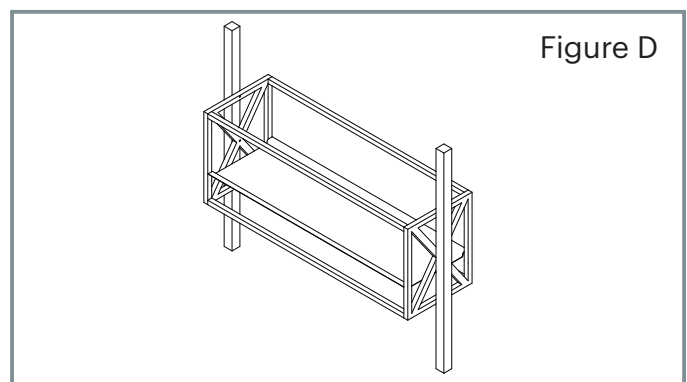

7. INSTALL BOX

Place the Box back in place, aligned with pre-drilled mounting holes. Use clamps to secure in place and ensure level. Using provided self-drilling metal screws, attach the Box to each Post. Remove clamps.

8. FINISH THE LOOK

When the Low Profile Assembly is fully installed, insert the Shelf Base in place. Repeat on top if using a Shelf Top. Using provided Metal Screws, attach Bottle Stops (optional) using the pre-drilled locations. Install mounting hole covers. (FIGURE E)

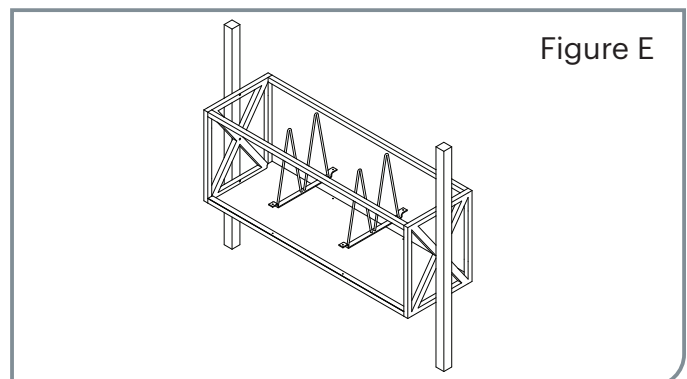

STORING BOTTLES

VintageView recommends stacking bottles to a maximum height of 4 total tall. Please also check stability of bottle stack as bottle shapes vary.

